

## Returns & Faulty Items

- If any problem is encountered during or after installation, please call the All LED technical department to get the problem resolved as soon as possible.
- Please do not just return the item to the outlet you purchased it from, as you are only entitled to a replacement or refund after the unit has undergone testing and the unit has been confirmed as having a manufacturing defect/fault. Your statutory rights are not affected.
- The manufacturer will not be deemed liable or held responsible for any damages caused by faults or manufacturing defects that may be present in any of its products or the misuse or incorrect installation of this device. Please refer to our troubleshooting guide for further information.
- All goods are supplied under the terms and conditions of All LED LTD, a copy of which may be obtained upon written request.

## General Information

- Interference may occur with other products on the same frequency of 2.4Ghz
- Product may differ in colour from image on box
- Range signal can be reduced when using within materials such as concrete & metal



### INSTALLATION GUIDE



### Smart-R AiQ/RLY1000M/LL

Relay Live/Live - Screw Terminal Module



## Technical Specifications

Product Code	AiQ/RLY1000M/LL
Operating Voltage (V)	100-240VAC
Input Current (A) Max	4.62A Max
Max Output Power (W)	1000W (Halogen); 400W (LED)
Output Voltage (Max)	100-240VAC
PF	0.99
Efficiency %	99%
Network Standby Power (W)	0.24W
Class	II
Body Material	White Polymer
Ingress Protection	IP20
Ambient Operating Temperature (°C)	-20°C ~ +50°C
Guarantee	5 Years
Minimum Load*	7W

\*May Require Load Stabiliser if <7W



ALL LED LTD  
42 Sedgwick Road,  
Luton, LU4 9DT

www.allledgroup.com  
sales@allledgroup.com  
Tel: +44 (0)208 841 9000

Environmental Protection  
Waste electrical products should  
not be disposed of with household  
waste. Please recycle where  
facilities exist. Check with your  
Local Authority or retailer for  
recycling advice



The manufacturer will not be deemed liable or held responsible for any damages caused by faults or manufacturing defects that may be present in any of its products or the misuse or incorrect installation of this device  
Your statutory rights are not affected.



## Pairing Instructions:

Initial programming of an entire system can be done as simply as: Fusebox Lighting Breakers OFF (5 Seconds), then ON.

Say "Alexa, add a device" or search on relevant app.

After the device has been added to a network successfully, a 3 minute window will open for find and bind (for remotes)

Network Mode: 60 Seconds

Find and Bind (for remotes): 3 Minutes

If the 1 minute window elapses, simply switch the module on and off. It will enter network pairing mode again.

### Network Pairing Mode:

This will automatically happen when the product is first switched on.

This mode enables the user to connect the smart module to a network hub/gateway. This mode will last 1 minute or until a connection has been established. If successful, the lights will flash. Once the time limit has elapsed, the module will go into a normal state, with a 3 minute window to pair any remotes. Once added to a network, the module must be factory reset if the network must be changed.

### Find and Bind Pairing Mode (Remote Control):

Note: If using the items on a smart device, you MUST pair the module and remote to the hub PRIOR to pairing with any remote control.

If using the module directly with a remote, you may proceed as below.

To set to this mode toggle the switch rapidly 4 times

From ON - OFF>ON>OFF>ON

Or push the program button on the module 4 times.

The pairing mode enables the user to connect or to disconnect from a remote device such as a handheld remote. The mode will only last up to 3 minutes or until the connection has been established. If successful, the lights will flash.

### Factory Reset:

To set to this mode toggle the switch rapidly 7 times

From ON - OFF>ON>OFF>ON>OFF>ON>OFF

Or push the program button on the module 7 times.

Factory reset mode will remove all paired connections to the module. If successful, the lights will flash. After the reset has completed the module automatically goes into network pairing mode.

## Dimensions

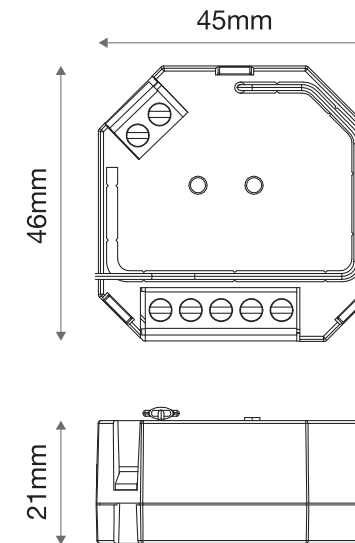

## Wiring Diagrams

### For Mains Wired Light Switch

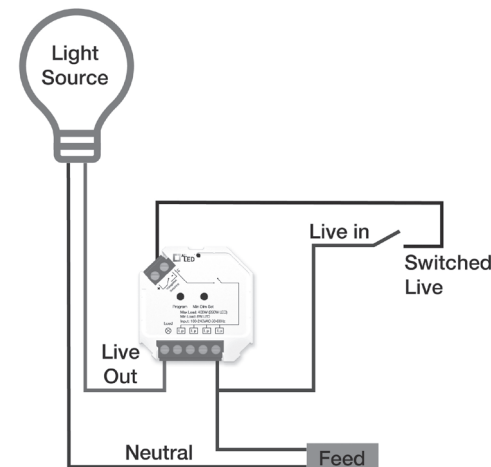

### For Low Voltage Light Switch\*

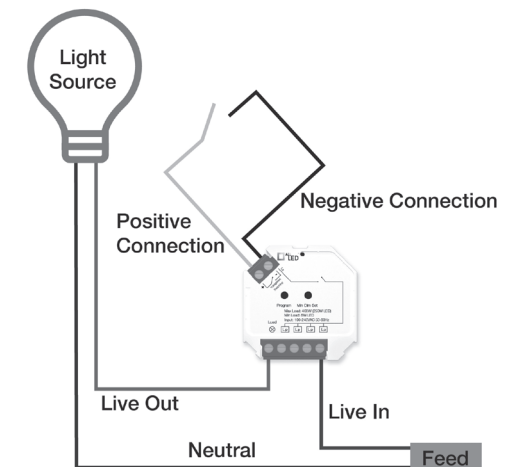

\*This option should be used with 1 switch only.  
For 2 way switching follow mains option